

P.L.V.



Manual lever hoist from 250 to 3000 kg



2, boulevard de l'Industrie - B.P. 59 - 28501 Vernouillet cedex - France

Tel. : (33) 02 37 38 95 95 - Fax : (33) 02 37 38 95 99

Internet : www.verlinde.com

JV 01 2001 PLV UGB

P.L.V.

Manual lever hoist

Hand lever block from 250 to 3000 kg



- 4 types with nice design, robust, compact, light and easy to handle.
- 1 year guarantee.
- Its new concept gives reliability with style.
- Chromium coating for hoist and lever
- The reinforced cover houses and protects the mechanism.
- It offers safety together with reduced weight and minimum maintenance.
- The lifting mechanism can be released when unloaded.
- It is tested according to current european standards and is supplied with a guarantee and test certificate.
- High resistance steel load chain.
- Rotating hooks with safety catch.

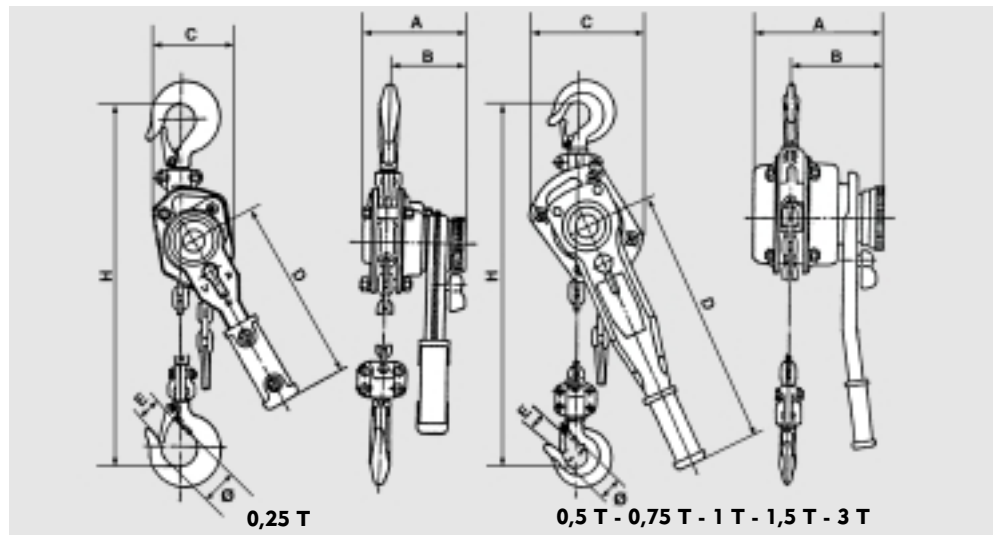

CHARACTERISTICS

Capacity (kg)		250	500	750	1000	1500	3000
Height of lift (m)		1,0	1,5	1,5	1,5	1,5	1,5
Pulling force under full load (N)	a	300	350	250	310	310	410
	b	282	315	225	280	287	380
Number of falls		1	1	1	1	1	1
Diameter of load chain (mm)		4	5	6	6	7	10
Min. distance between H (mm)		245	310	310	320	385	460
Length of lever handle: D (mm)	a	158	278	278	278	378	388
	b	168	308	308	308	408	418
Dimensions (mm)	A	92	110	149	149	171	204
	B	71	84	89	89	102	114
	C	70	125	128	128	145	203
	Ø	31	35	37	40	45	55
	E	20	23	26	31	36	44
Net weight (kg)		2,1	4,8	6,2	6,5	9,5	20,2



VERLINDE

2, boulevard de l'Industrie - B.P. 59 - 28501 Vernouillet cedex - France

Tel. : (33) 02 37 38 95 95 - Fax : (33) 02 37 38 95 99

Internet : www.verlinde.com

JV 01 2001 PLV UGB